

Application diagrams

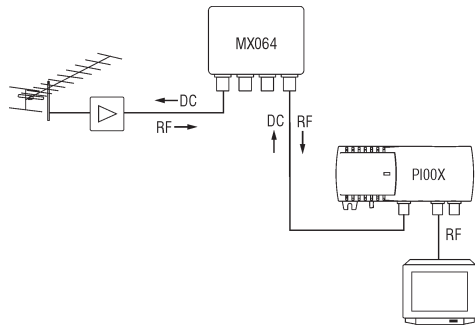

Figure 2. Recommended to use TERRA power supplies PI008, PI009, PI011.

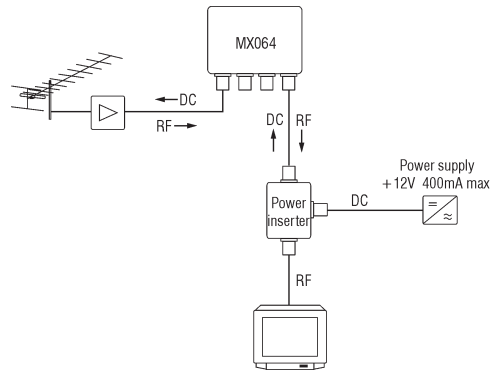

Figure 3. Application diagram using other power supplies 12 V 400 mA max., connected together with power inserter.

Technical characteristics

Type		MX061	MX062	MX064	MX065	MX066A
Gain	FM (88-108 MHz)	16 dB	30 dB	30 dB	30 dB	16 dB
	VHFIII (174-260 MHz)				30 dB	
	UHFIV (470-566 MHz)	-	-	-	-	22 dB
	UHFV (590-790 MHz)	-	-	-	-	22 dB
	UHF (470-790 MHz)	2x20 dB	2x34 dB	38 dB	38 dB	-
Number of inputs	3	3	2	3	3	
Noise figure	VHF 6 dB; UHF 3 dB					
Max.output level	IMD3=60 dB (DIN45004B)	108 dB μ V				
		105 dB μ V				
Gain control	VHF 0 ÷ -10 dB	VHF 0 ÷ -20 dB; UHF 0 ÷ -16 dB			VHF 0 ÷ -10 dB	
	UHF 0 ÷ -10 dB				UHF 0 ÷ -10 dB	
Return loss	> 10 dB					
DC feeding for preamplifier	12 V \approx 60 mA					
Current consumption*	12 V \approx 65 mA	12 V \approx 80 mA			12 V \approx 65 mA	
Operating temperature range	-20° ÷ +50 °C					
Dimensions/Weight (packed)	89x107x43 mm/0.18 kg					

* without external DC loading

Multiband amplifiers MX061, MX062, MX064, MX065, MX066A

Product description

Multiband masthead amplifiers are intended for summing and amplifying TV signals from up to 3 antennas in FM, VHF (6-12 channels) and UHF (21-60 channels) bands.

The amplifiers are powered via a coaxial cable (4). Supply voltage is 12V DC. External power supply must have a short circuit protection.

There is a possibility to feed the antenna amplifier through one of the UHF inputs (1), MX066A - through UHFV input. This voltage is switched on by switch (6). Total power supply output current must be checked before switching it on, to provide enough power for both amplifiers (antenna and masthead) combined. Do not switch on the switch if antenna has no antenna amplifier.

There is a possibility to adjust the gain of the amplifier in every sub-band. The gain increases by turning regulator (5) clockwise. The amplifier can be used in outdoor conditions as well.

Safety instructions

Installation of the amplifier must be done according IEC60728-11 and national safety standards. Any repairs must be done by a qualified personnel.

The amplifier is powered (+12V) from external power supply, therefore there is no danger for life.

External power supply must have a short circuit protection.

Do not plug the external power supply until all cables have been connected correctly.

To disconnect the amplifier, disconnect the power supply from mains or disconnect the cable from output connector.

The amplifier should be mounted with connectors underneath to avoid the water ingress inside.

External view

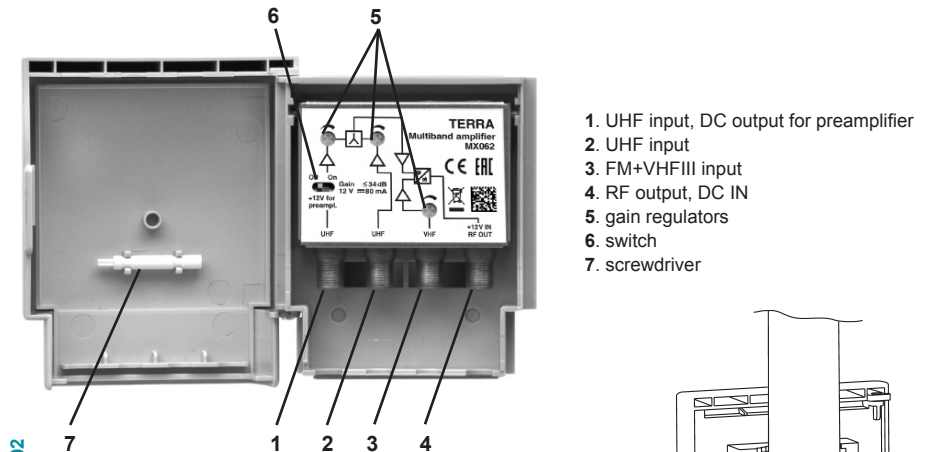

Figure 1. External view of the amplifier

Vers. 1.02

INSTALLATION INSTRUCTIONS

Read the product description and safety instruction first.

If the input connector is not used, terminate it with 75 Ω load and set the minimum gain of corresponding band.

The amplifier should be mounted with connectors underneath.

The plastic belt enclosed in the product package is intended for mounting amplifier to the antenna mast (see Figure 2).

Gain of every sub-band can be adjusted with screwdriver (7).

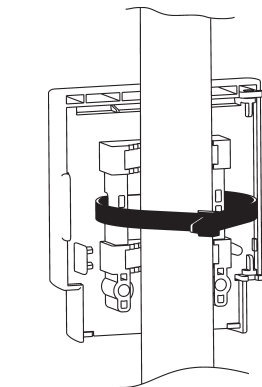

Figure 2. Mounting of the amplifier to the antenna mast