

DSP40_{PRO+}

Digital Signal Processor

TV Terrestrial programmable amplifier

- ▶ Total output level max 126dB μ V
- ▶ 50dB digital filters on adjacent channels
- ▶ Single filter selectable mode Standard/Narrow/Wide
- ▶ Channel to channel conversion
- ▶ Manual filter level adjustment (1)
- ▶ Filter frequency OFF-SET adjustment (1)
- ▶ UHF inputs Lte 700 filter with SAW technology
- ▶ Dual-stage input amplifiers
- ▶ Wide band AUX (40... 860MHz) input
- ▶ DAB filter 174... 230MHz
- ▶ Automatic Channel search from all inputs
- ▶ Manual programming from display and APP

(1) Function only accessible with smartphone programming.

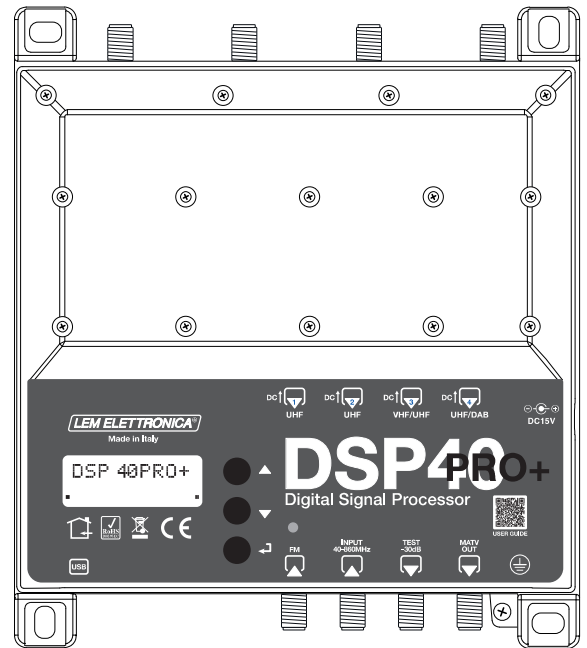

TECHNICAL SPECIFICATIONS		
NUMBER OF INPUTS	6	1 FM; 2 UHF; 1 VHF/UHF; 1 DAB/UHF ; 1 AUX
INPUTS FREQUENCY RANGE	MHz	FM (40... 108) AUX (40... 862) BIII/DAB 170... 240 / UHF 470... 694/862
SINGLE CHANNEL FILTERS		32
NUMBER OF CHANNEL PER FILTERS		1
INPUT LEVEL RANGES	dB μ V	FM 35... 90 - BIII/DAB 40... 110 - UHF 40... 110
FILTERS SELECTIVITY	dB	>50 (Adjacent channels)
AUTOMATIC CONTROL GAIN RANGE	dB	40 dB
VHF/UHF INPUTS AMPLIFIER GAIN		0 / +15 / +30
FM GAIN	dB	45 (Adjustable 0... -30dB)
AUX GAIN	dB	40 (Adjustable 0... -20dB)
VHF GAIN	dB	60
UHF GAIN	dB	75
SELECTABLE FILTERS BANDWIDTH		AUTO - NARROW/STANDARD/WIDE
OUTPUT LEVEL RANGE	dB μ V	99... 119
FILTER LEVEL ADJUSTER	dB	-5... +5 (1dB step)
FILTER OFFSET ADJUSTER	KHz	-500... +500 (125KHz steps)
UHF ADJUSTABLE SLOPE	dB	0... -5
VHF ADJUSTABLE OUTPUT	dB	0... 10 (1 dB step)
MAX TOTAL VHF-UHF OUTPUT LEVEL	dB μ V	126 DIN 45004B
INPUTS REMOTE POWER		12V / 24V 100 mA
RETURN LOSS IN/OUT	dB	>12
TEST OUTPUT		1 (-30 dB)
AMPLIFIER POWERING		100...240VAC 50/60Hz (External power supply 15VDC / 1,25A)
MAX AMPLIFIER CONSUMPTION	W	10,50
MAX AMPLIFIER CONSUMPTION + REMOTE POWER	W	12,50
OPERATING TEMPERATURE	°C	-5... 50
DIMENSIONS	mm	192 x 217 x 37

Product icons description



The **DSP40pro+** amplifier is covered by an extended 5-year warranty from the date of manufacture.



The UHF inputs are protected by SAW technology filters against 5G and 4G LTE interference.



The DSP40pro+ amplifier can also be programmed via a free graphic application available for Android OS.



The **AUTO-TUNING** scanning function serves to speed up the programming procedure by automatically storing DVB-T/T2 Channel's.

Description of symbols and electrical safety



Product complies with CE marking requirements



Installation is only permitted in dry rooms and on a non-flammable surface. Ensure that there is adequate air circulation.



Symbol indicating earth terminal



Symbol indicating that the supplied mains power supply complies with the safety requirements for class II devices.



To avoid risk of fire or electrocution, do not open the mains power supply provided.



RoHS 2011/65EU compliant product.



Pursuant to Article 24 of Legislative Decree No. 49 of 14 March 2014 "Implementation of Directive 2012/19/EU on waste electrical and electronic equipment (WEEE)". The crossed-out wheeled bin symbol on the equipment or its packaging indicates that the product at the end of its useful life must be collected separately from other waste for proper treatment and recycling.

Package Contents

01 DSP40pro+ programmable amplifier

01 Power supply YS25-1501250 (100... 240VAC 50/60Hz 0.5A - 15VDC 1.25A)

08 Dowels 6x30mm with screws 4.5x40mm

01 User Manual

Installation warnings

- Use only the supplied power supply unit.
- To ensure adequate cooling and ventilation, the **DSP40pro+** control unit and power supply unit must be securely fixed to a vertical wall.
- To avoid the risk of fire or electrocution, do not expose the products to rain or moisture.
- Products must not come into contact with water or be wetted by liquids.
- Do not place products near heat sources or in places with moisture.
- In the case of installation in a cabinet or recessed compartment, provide adequate ventilation and observe the minimum distances given in the drawing below.
- Prepare the mains connection in accordance with the regulations in force in the country of installation and in such a way that the power supply to the control unit can be easily disconnected.

Connections and start-up

- 1) Proceed with the connection of the coaxial input and output cables equipped with their own earth terminal block.
- 2) Close the inputs with 75Ω terminations (code RCS75).
- 3) Connect the power supply to the mains socket only after all other connections have been made.
- 4) Always use the test output for connecting measuring instruments.

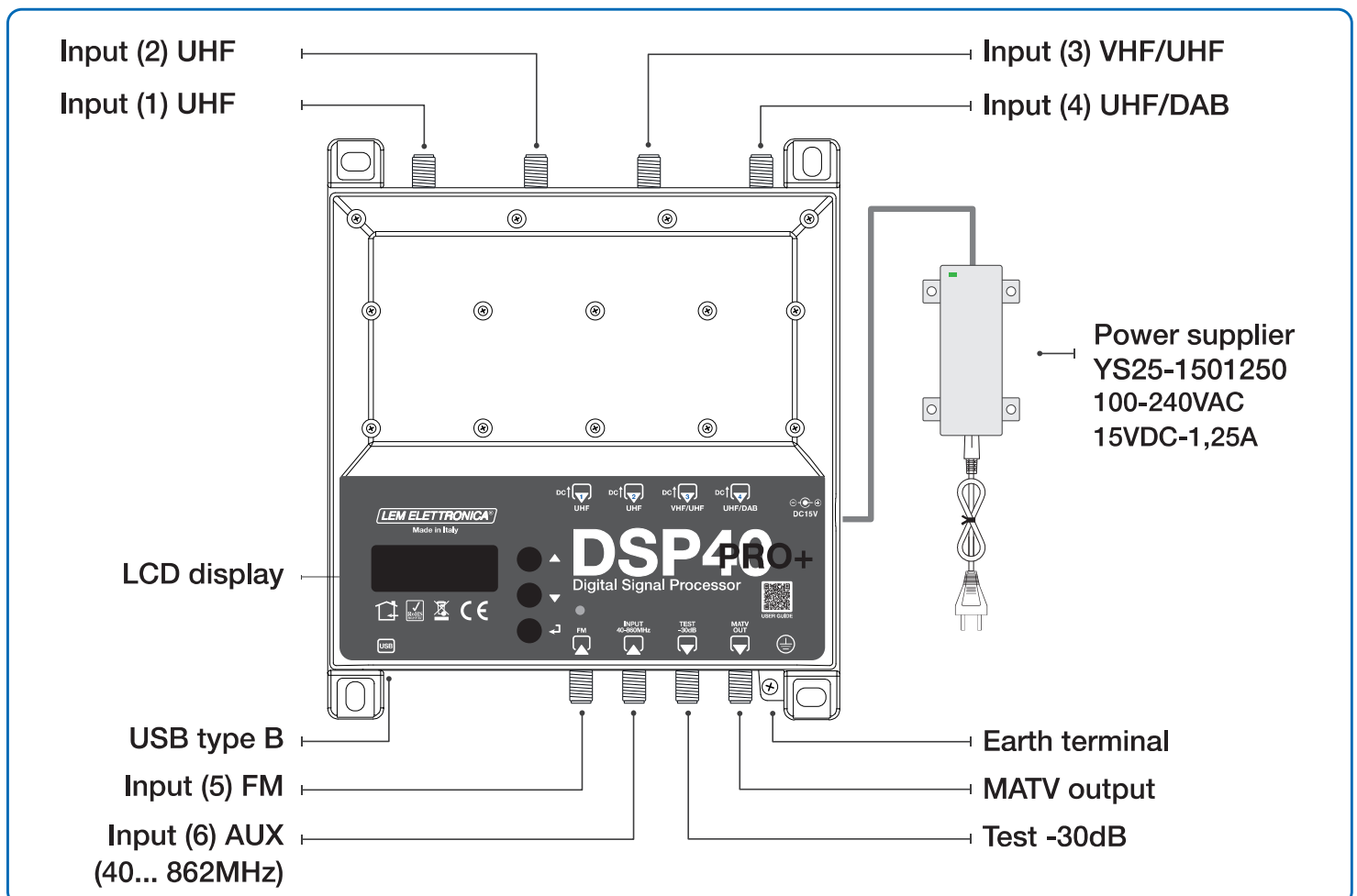

Application examples

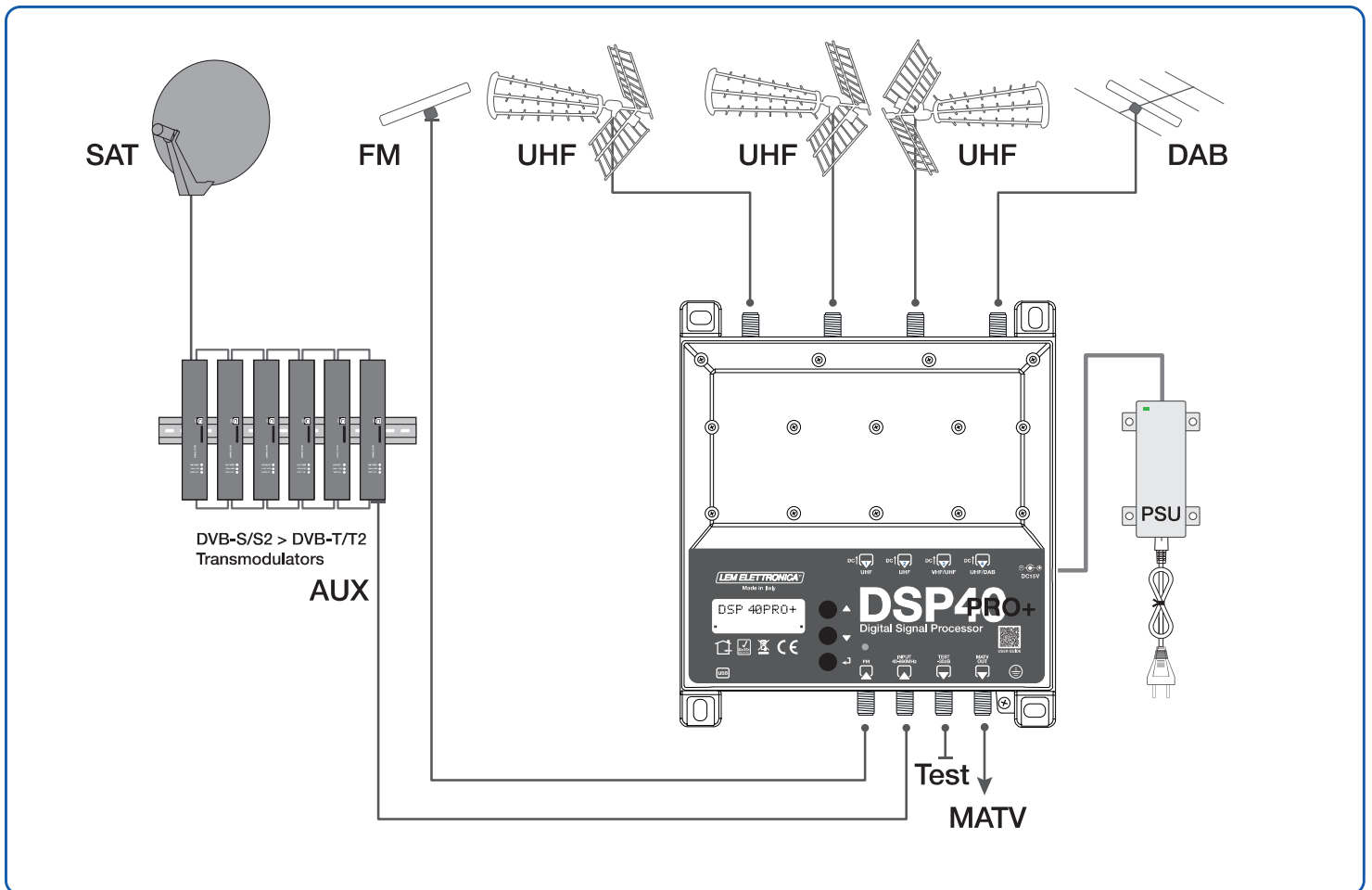
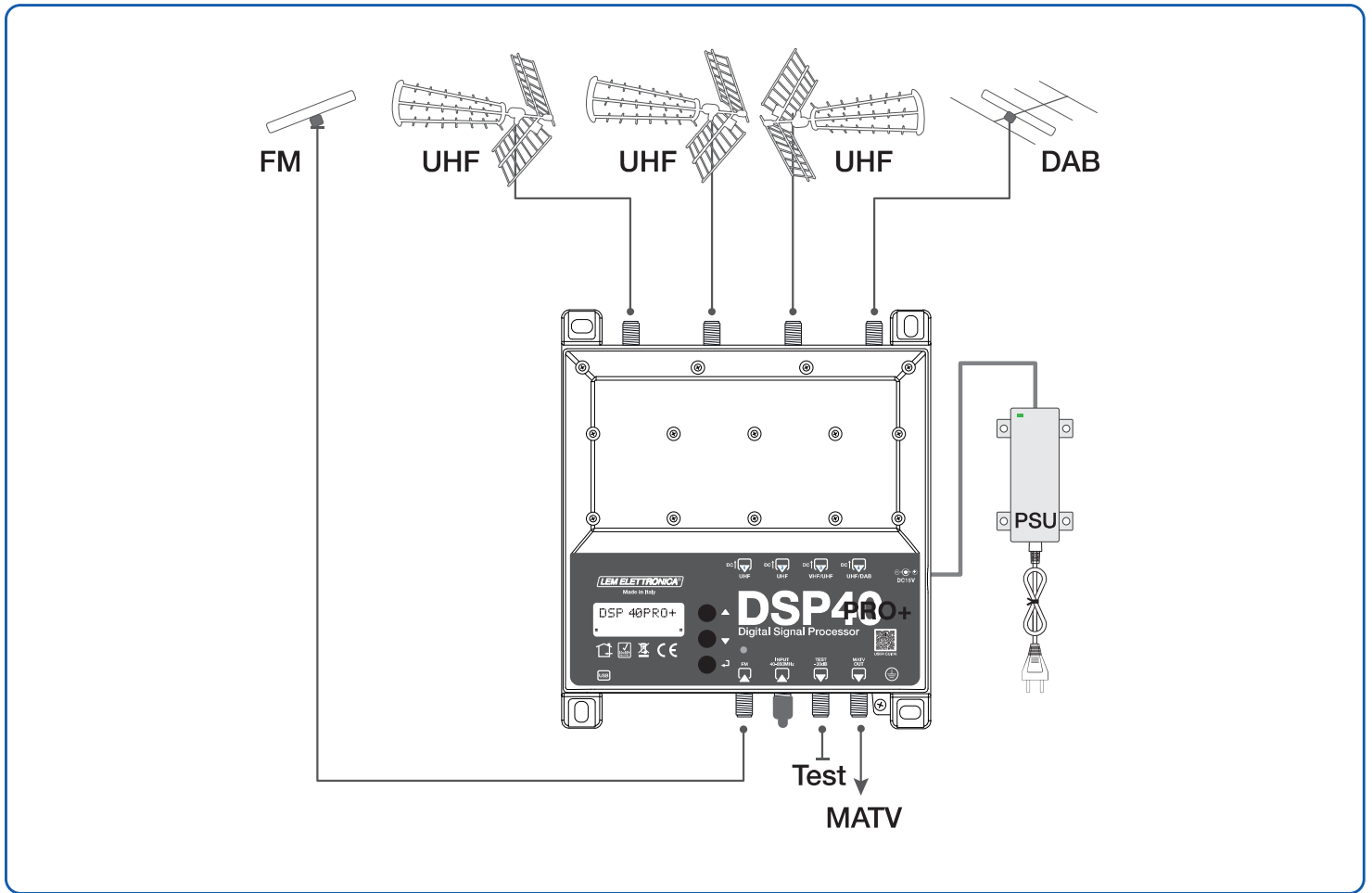

Device Programming

The **DSP40pro+** programmable amplifier can be configured in two different ways:

- 1) using the display and navigation keys integrated into the control unit.
- 2) using the **LEM USB** application for Android smart phones, which can be downloaded free of charge from the Google Play Store.

Description of display use

- To activate the display, briefly press the $\leftarrow \downarrow$ key.
- To access the menus, press and hold the $\leftarrow \downarrow$ key for 3 seconds.
- To make a value in the display editable, position the function selector \rightarrow using the navigation keys $\nabla \Delta$. Pressing $\leftarrow \downarrow$ will activate the pointer under the data, which can be modified with $\nabla \Delta$ keys. To confirm the change press $\leftarrow \downarrow$.

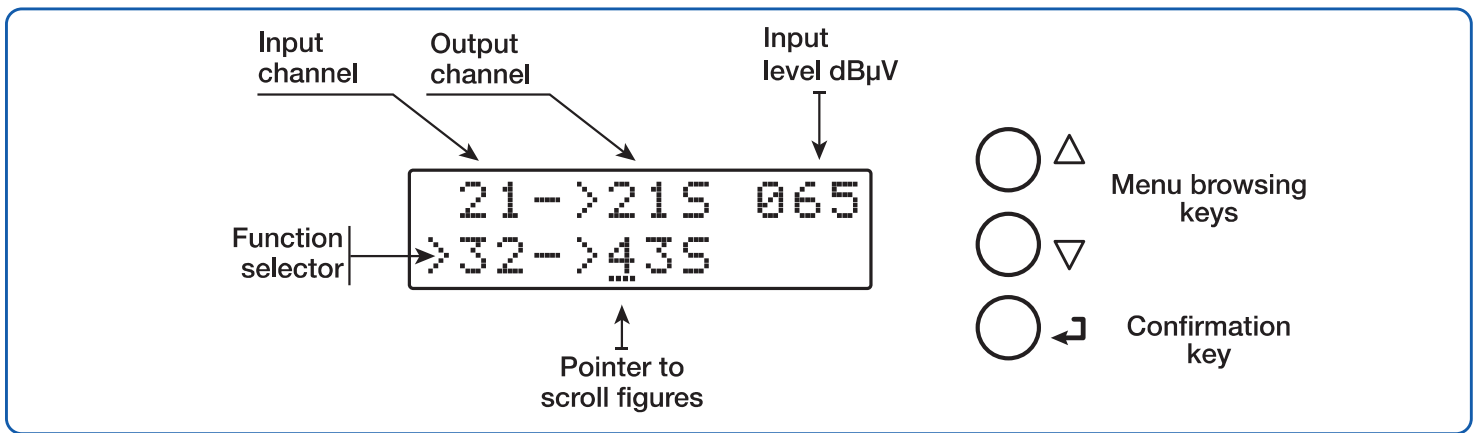

Note: after 3 minutes of inactivity the display switches off but the menu remains open on the last selected function. To resume press any key



To return to the main level menu from any sub-menu, simultaneously press the $\nabla \Delta$

Automatic Channel Programming

To speed up the programming process, you can use the **AUTO-TUNING** function. When this function is activated, the **DSP40pro+** amplifier will automatically scan the inputs (1; 2; 3; 4) and store only DVB-T/T2 signals with a level equal to or higher than the **THRES** threshold (factory setting 55dB μ V).



```
TUNING
AUTO    MAN
```

To start the **AUTO-TUNING** procedure select **AUTO** and press \leftarrow . For best results, you will be asked to confirm some parameters before starting the scan.

REMOTE POWER SUPPLY

```
>DC:12V
DC IN1:OFF
```

Choose **12V** or **24V** for the remote power supply that will be provided by the inputs that will be activated in the next step.

```
>DC IN1:OFF
DC IN2:OFF
```

Switch on the remote power supply on the inputs that are to supply an active antenna or an external amplifier.

```
ERROR
OVERCURRENT!
```

The presence of a short circuit or overload at the inputs is signalled by the flashing red light, green **POWER LED** and the display.



LTE FILTER ACTIVATION

```
>LTE:5G
THRES:055dB
```

Selecting **5G** will activate the Lte4/5G interference protection SAW filters and the UHF channel search range will be limited between **E21** and **E48**. Selecting **OFF** will disable Lte5G protection and extend the search to the entire **UHF** band (E21... E69).

THRESHOLD LEVEL

```
>THRES:055dB
START
```

The 55dB μ V factory threshold is optimal for most situations, but it is possible to change it.

THRES > 55dB= lower search sensitivity

THRES < 55dB= higher search sensitivity

AUTO-TUNING START

```
>START
EXIT
```

Select **START** to start automatic channels scanning. The duration of the **AUTO-TUNING** procedure depends on the number of channels received from the connected antennas.

```
TUNING  ✕
WAIT
```

```
OUTPUT
>LEV:110dBuV
```

Once the **AUTO-TUNING** procedure is complete, the display will show the total output level calculated according to the number of channels found in the scan. To confirm and complete the procedure press the \leftarrow key. If you wish to change the value of the output level, use the ∇ Δ keys and confirm by pressing the \leftarrow key.

Note:

An output level higher than that obtained automatically can lead to a degradation of signal quality.

Menu description

```
TUNING
AUTO          MAN
```

To start manual programming, select MAN using the ▾ key and press ↵.

INGRESSO (1) UHF

```
IN (1)  UHF
```

To set input parameters (1) press ↵.

REMOTE POWER SUPPLY

```
IN (1)  UHF
>DC:OFF
```

To enable remote feed from input (1) press ↵ and use the ▾ Δ keys to select **ON / OFF** and confirm by pressing ↵ again.

The 12/24V selection can be found in the **ADVANCED** menu

INPUT AMPLIFIER

```
DC:OFF
>AMPLI:MID
```

Press ▾ to set function switch > to AMPLI and press ↵ and use the ▾ Δ keys to select OFF/MID/HIGH confirm by pressing ↵ again.

INPUT SIGNAL LEVEL	AMPLIFIER
Higher than 85dBμV	OFF
Between 55dBμV and 85dBμV	MID
Less than 55dBμV	HIGH

CHANNEL FILTER

```
AMPLI:MID
>ADD 1CH
```

Press ▾ to position function switch > to **ADD 1CH** and press ↵. To select the channel number use the ▾ Δ keys; to confirm that the output channel is the same as the input channel press ↵ twice.

```
>21->215 065
ADD 1 CH
```

```
>21->215 065
ADD 1 CH
```

CHANNEL CONVERSION

```
>21->345 065
ADD 1 CH
```

To convert a Channel to a different channel from the one received as input, place the pointer under the output filter and select the channel number using the ▾ Δ keys, press ↵ to confirm.

LTE 5G FILTER	INPUT CH.	OUTPUT CH.
ON	E21÷E48	E21÷E69
OFF	E21÷E69	E21÷E69

LTE 5G filter management in **ADVANCED** menu

FILTER BANDWIDTH

```
>21->215 065
ADD 1 CH
```

To manually assign a filter bandwidth press **←** again and use the **∇****Δ** keys to choose the most suitable filter.

FILTER	DESCRIPTION	USE SUGGESTION
N	Narrow	Adjacent
S	Standard	Not-adjacent
W	Wide	Not-adjacent low quality

Note: The presence of the letter **A** indicates that automatic filter management has been selected in the **ADVANCED** menu. To change it to manual access the **ADVANCED** menu and select **BW: MAN.**

OVERLAPPING FILTERS

```
23->235*065
>23->235*065
```

The overlapping of two or more filters with the same output channel is indicated by the symbol *****.

DELETE FILTER

```
CH DELETED
```

Select a channel filter or conversion and press **←** for 5 seconds to delete.

INPUT (2) UHF

```
IN (2) UHF
```

To set the input parameters (2) press **←** and access the menu. For programming, follow the instructions described for **INPUT (1) UHF.**

INPUT (3) VHF/UHF

```
IN (3) V/UHF
```

To set input (3) parameters, press **←** to access the menu. For programming, follow the instructions described for **INPUT (1) UHF**

LTE 5G FILTER	INPUT CH.	OUPUT CH.
ON	E5÷E13/E21÷E48	E5÷E13/E21÷E69
OFF	E5÷E13/E21÷E69	E5÷E13/E21÷E69
LTE 5G filter management in ADVANCED menu		

INPUT (4) UHF

```
IN (4) UHF
```

To set input (4) parameters, press **←** to access the menu. For programming, follow the instructions described for **INPUT (1) UHF**

INPUT (4) DAB

```
IN (4) DAB
```

To activate the input filter for the DAB band select **ON**. The **DAB** filter has its own amplifier that can be set to three levels.

```
: ON
>AMPLI: MID
```

AMPLIFIER	GAIN
OFF	-8 dB
MID	0 dB
HIGH	+15 dB

Note: Activating the DAB filter does not exclude the possibility of process UHF channels from the same input so COMBO DAB-UHF antennas can be used.

INPUT (5) FM

```
IN (5) FM
```

Input **(5)** is dedicated to the FM radio band. To adjust the input attenuation press **↵** and use the **▽ Δ** keys to set the desired level.

```
IN (5) FM  
>ATTEN: -15dB
```

INPUT (6) AUX

```
IN (6) AUX
```

Input **(6)** is wideband from 40 to 860Mhz and is ideal for amplifying signals generated by A/V modulators or DVB- S/S2 > DVB-T/T2 transmodulation systems. To adjust the input attenuation press **↵** and use the **▽ Δ** keys to set the desired level.

```
IN (6) AUX  
>ATTEN: -15dB
```

OUTPUT LEVEL

```
OUTPUT
```

Press **▽** to select the OUTPUT menu and confirm with **↵** to access the amplifier output level setup.

```
OUTPUT  
>LEV: 119dBuV
```

To set the output level, press **↵** and use the **▽ Δ** keys to change the numerical value. To confirm, press **↵** again.

SLOPE

```
LEV: 119dBuV  
>SLOPE: 05dB
```

To correct the slope of the output, set the pointer **>** to SLOPE and press **↵**, use the **▽ Δ** keys to change the value and press **↵** to confirm.

VHF OUTPUT LEVEL

```
SLOPE: 05dB  
>VHF: -00dB
```

To change the VHF level output, select VHF and press **↵**; use the **▽ Δ** keys to change the value and press **↵** to confirm.



To return to the main level menu from any submenu, press and hold the **▽ Δ**

ADVANCED SETTINGS

ADVANCED

PROTECTION PASSWORD

ADVANCED
>PASSW: 000

Select **PASSW**, press **↵** and use the **▽ Δ** keys to choose the numerical value of the first digit on the right and confirm with **↵**. For the next two digits, repeat the operation and press **↵** to confirm.

Code 0 0 0 equals no password protection

Lte 5G FILTER

PASSW: 000
>LTE: 5G

Press **↵** and use the **▽ Δ** keys to enable or disable the Lte5G SAW filters, press **↵** to confirm.

Lte 5G FILTER	INPUT CHANNELS
ON	E21÷E48
OFF	E21÷E69

PASSW: 000
>LTE: OFF

REMOTE POWERING

LTE: 5G
>DC: 12V

To set the **DC** voltage press **↵** and use the **▽ Δ** keys to select **12V** or **24V** voltage confirm by pressing **↵**.

The selected remote supply voltage will be the same for all inputs.

FILTERS BANDWIDTH

DC: 12V
>BW: MAN

In **MAN** (manual) mode three different filters (**N - S - W**) will be selectable in the **INPUT** menus. If **AUTO** is set, the filters will be assigned automatically.

DC: 12V
>BW: AUTO

THRESHOLD LEVEL

BW: AUTO
>THRES: 055dB

The **THRES** value determines the sensitivity of the **AUTO- TUNING** scan and the intervention threshold of the **MONITOR** function.

FAST FUNCTION

THRES: 055dB
>FAST: ON

Activation of the **FAST** function reduces the adjusting time of the **CAG** (automatic gain control). This function is useful in the presence of unstable channels with sudden changes in their level.

MONITOR FUNCTION

```
FAST: OFF
>MONITOR: OFF
```

Activation of the **MONITOR** function, a continuous cyclic check of all the programmed filters, disabling those that are not affected by the transmission of a channel. The switch-off threshold is set by the **THRES** value described in the **THRESHOLD LEVEL** function.

SERIAL NUMBER

```
MONITOR: OFF
>SRNBR: 12345
```

The number series to the right of **SRNBR** represents the serial number of the product.



To return to the main level menu from any submenu, press and hold the **▽ Δ**

RESET

```
RESET
```

If you wish to delete all settings and restore the control unit to factory state, select **YES** and confirm **↵**. The display will show the message **OP EXECUTED** to confirm the successful cancellation operation.

```
ARE U SURE?
YES          NO
```

```
OP
EXECUTED
```

EXIT

```
EXIT
```

To end the programming procedures select **EXIT** pressing **↵** and select with **▽ Δ YES** press **↵** to confirm. If you wish to continue programming select **NO** and confirm with **↵**.

```
ARE U SURE?
YES          NO
```

Android SmartPhone Programming

Requirements

The **DSP40pro+** can also be programmed by the **LEM USB** App available for Android smartphones, which can be downloaded free of charge from the Google Play portal.

To check whether your device's USB port supports **OTG** (On The Go) mode, please refer to the user manuals of your smartphone/tablet, failing which you can check **OTG** compatibility with a free APP called **USB OTG Checker** that can be downloaded from the Google Play portal.

A **USB-OTG** cable or adapter is required to connect and programme the **DSP40pro+**



LEM USB

Setup

- 1 Power up the control unit and wait for the LCD display to show **DSP40 PRO+**.
- 2 Connect the USB port of your Android device with the **USB-B** port integrated in the **DSP40pro+** control unit using the appropriate USB-OTG cable.
- 3 If the connection procedure was successfully completed, the **LEM USB** application will start automatically allowing all programming operations.

Note: the channel manual level adjustment functions **LEVEL ADJ** and offset **FREQ ADJ** are accessible only on the **LEM USB APP**.

Label with serial and tracking data

AA1000015019-X1020L

AA	100001	50	19	X	10	20	L
Model	Serial #	Manuf. Week	Manuf. Year		HW Rel.	FW Rel.	

